

REVISIONS			
REV	DESCRIPTION	DATE	APPROVED
None	First issue.	1 SEPT 2011	JY

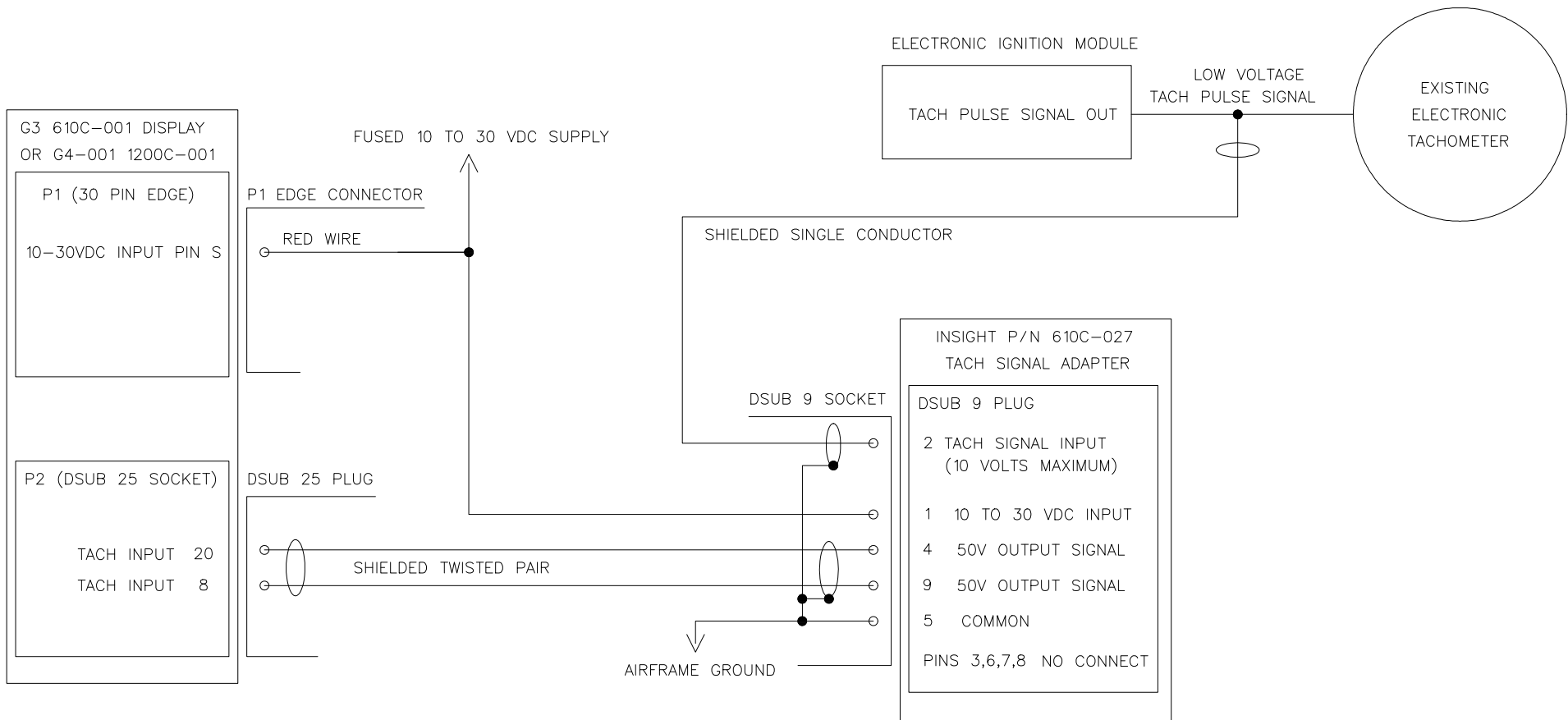

NOTES:

1. Use 24 AWG copper wire with TEFZEL or equivalent insulation unless otherwise specified.
2. Consult with Insight for equipment compatibility.
3. Do not mount adapter in engine compartment.
4. Single engine GEM shown. Twin engine GEM (G4-002) similar, use one adapter per engine, see drawing G4-315 for DSUB-37 TACH pin numbers.

<h1 style="margin: 0;">Insight</h1>	TACH SIGNAL ADAPTER WIRING DIAGRAM						
	Insight Avionics Inc. Box 122, Fort Erie, Ontario L2A 5M6						
This drawing is the property of Insight Instrument Corporation and contains confidential and proprietary information. Reproduction or unauthorized use is strictly forbidden. © Copyright 2011	SIZE A	FILE NAME: tsawd	DRAWING NO. 101123	DRN JY	CKD JY	QCD JY	REV -
SCALE NONE	DATE 1 SEPT 2011	SHEET 1 OF 1					