

GPS AND AIR-DATA COMPUTER WIRING
FOR G4 TWIN ENGINE AND G9 SINGLE ENGINE

REVISIONS			
REV	DESCRIPTION	DATE	APPROVED
A	First issue.	10 DEC 10	JY
B	Added notes for GPS.	24 JAN 13	JY
C	Added notes for single engine installation.	1 OCT 13	JY

G4-002 MOD. A GEM DISPLAY

P2 (D-SUB 37 RECEPTACLE) D-SUB 37 PLUG

COM3 RXD	14
DGND	33
COM2 RXD	24
COM3 TXD	32
RESERVED A	31
RESERVED B	13
RESERVED	25

USE THIS CONFIGURATION TO CONNECT TO A GPS AND A TAS-1000 SYSTEM.

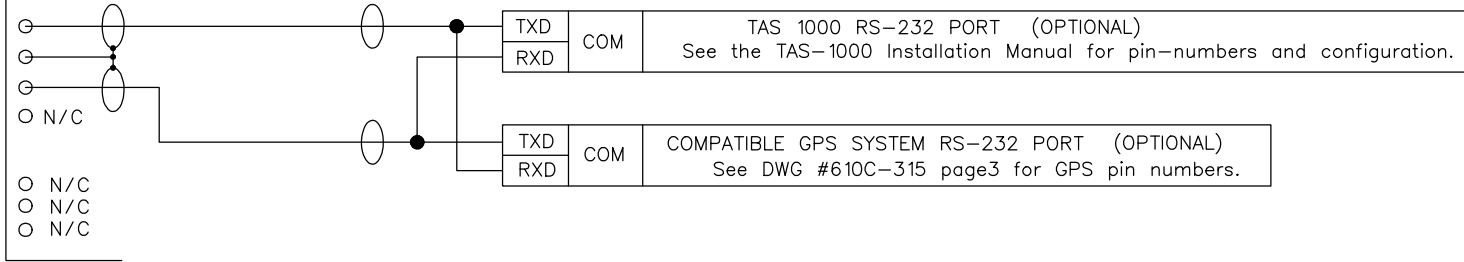

COM3 RXD	14
DGND	33
COM2 RXD	24
COM3 TXD	32
RESERVED A	31
RESERVED B	13
RESERVED	25

USE THIS CONFIGURATION TO CONNECT TO A GPS WITH NO TAS-1000 SYSTEM.

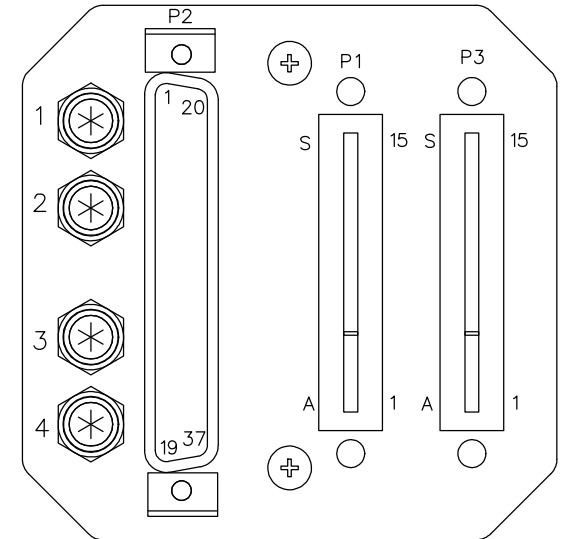
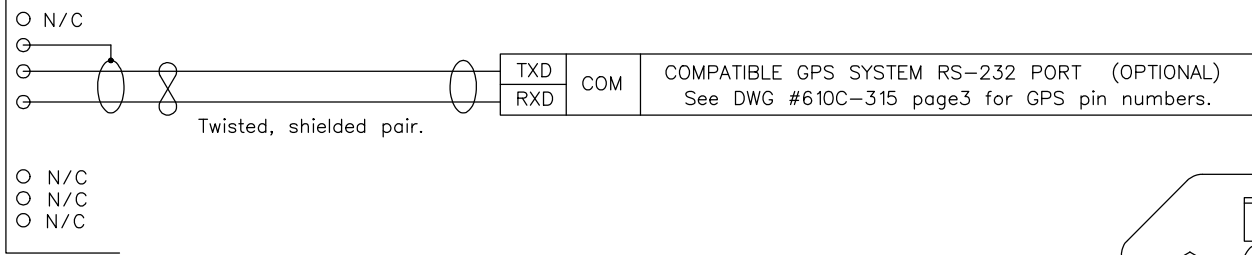

NOTES:

1. Use 24 AWG copper wire with TEFZEL or equivalent insulation unless otherwise specified.
2. Refer to the TAS-1000 Installation Manual for pin numbers and configuration.
3. Refer to the GPS manufacturers data for pin numbers and configuration.

Insight

G4/G9 DSUB 37-PIN INTERCONNECT DIAGRAM

Insight Avionics Inc.
Box 122, Fort Erie, Ontario L2A 5M6

This drawing is the property of Insight Instrument Corporation and contains confidential and proprietary information. Reproduction or unauthorized use is strictly forbidden.
© Copyright 2010

SIZE	FILE NAME:	DRAWING NO.	DRN	CKD	QCD	REV
	G4in3C	G4-315	JY	JY	JY	C
SCALE	DATE	SHEET	3 OF 3			
NONE	1 OCT 13					

FUEL FLOW AND VIBRATION SENSOR WIRING FOR G4 TWIN AND G9 SINGLE

G4-002 GEM DISPLAY
MOD. A
P2 (DSUB 37 SOCKET)

REVISIONS			
REV	DESCRIPTION	DATE	APPROVED
A	FIRST ISSUE	10 DEC 10	JY
B	Changed vibration sensor connector from 7 to 6 pins.	24 JAN 13	JY
C	Added notes for single-engine installation.	1 OCT 13	JY

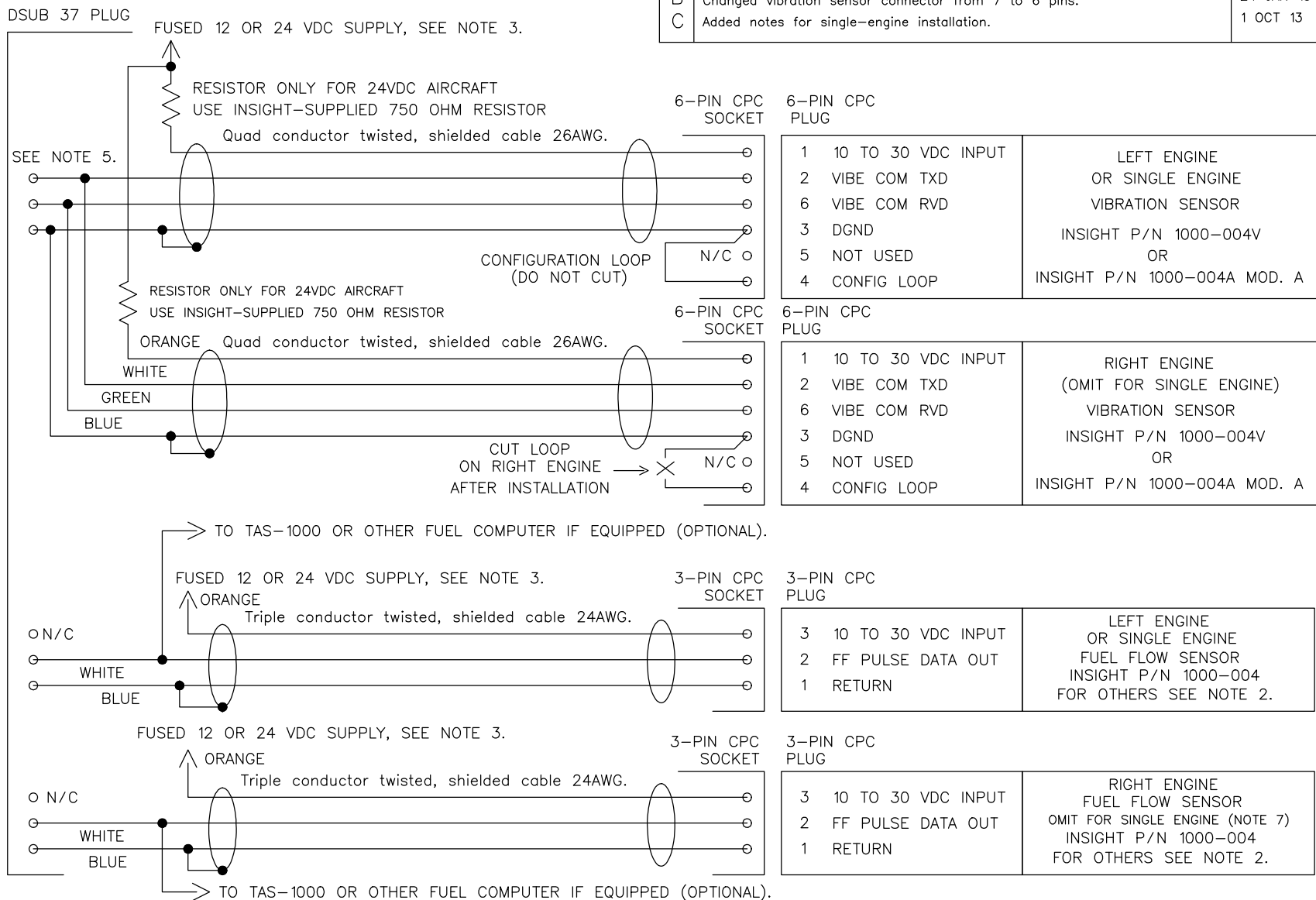

COM 1 RVD 23
COM 1 TXD 5
DGND 4

FF1A 12
FF1 11
FF1-GND 30

FF2A 35
FF2 16
FF2-GND 17

6-PIN CPC SOCKET	6-PIN CPC PLUG	LEFT ENGINE OR SINGLE ENGINE VIBRATION SENSOR INSIGHT P/N 1000-004V OR INSIGHT P/N 1000-004A MOD. A
1	10 TO 30 VDC INPUT	
2	VIBE COM TXD	
6	VIBE COM RVD	
3	DGND	
5	NOT USED	
4	CONFIG LOOP	

6-PIN CPC SOCKET	6-PIN CPC PLUG	RIGHT ENGINE (OMIT FOR SINGLE ENGINE) VIBRATION SENSOR INSIGHT P/N 1000-004V OR INSIGHT P/N 1000-004A MOD. A
1	10 TO 30 VDC INPUT	
2	VIBE COM TXD	
6	VIBE COM RVD	
3	DGND	
5	NOT USED	
4	CONFIG LOOP	

3-PIN CPC SOCKET	3-PIN CPC PLUG	LEFT ENGINE OR SINGLE ENGINE FUEL FLOW SENSOR INSIGHT P/N 1000-004 FOR OTHERS SEE NOTE 2.
3	10 TO 30 VDC INPUT	
2	FF PULSE DATA OUT	
1	RETURN	

3-PIN CPC SOCKET	3-PIN CPC PLUG	RIGHT ENGINE FUEL FLOW SENSOR OMIT FOR SINGLE ENGINE (NOTE 7) INSIGHT P/N 1000-004 FOR OTHERS SEE NOTE 2.
3	10 TO 30 VDC INPUT	
2	FF PULSE DATA OUT	
1	RETURN	

NOTES:

1. Use 24 AWG copper wire with TEFZEL or equivalent insulation unless otherwise specified.
2. For connection to other fuel flow sensors use P/N 610C-025, see Drawing no. 101116A.
3. Connect FF and vibration sensor VDC inputs to same +V supply as GEM P1-harness, Pin S.
4. Note that a 750 Ohm resistor is required for each vibration sensor in 24 Volt aircraft.
5. Use pigtail connections where multiple wires connect to a single pin.
6. Refer to TAS-1000 Installation Manual for pin-numbers.
7. May be configured for single engine return fuel line, contact Insight.



G4/G9 DSUB 37-PIN INTERCONNECT DIAGRAM

Insight Avionics Inc.
Box 122, Fort Erie, Ontario L2A 5M6

This drawing is the property of Insight Instrument Corporation and contains confidential and proprietary information. Reproduction or unauthorized use is strictly forbidden.
© Copyright 2010

SIZE	FILE NAME: G4in2C	DRAWING NO. G4-315	DRN	CKD	QCD	REV C
SCALE	DATE	SHEET				
NONE	1 OCT 13	2 OF 3				

REVISIONS			
REV	DESCRIPTION	DATE	APPROVED
A	First issue.	10 DEC 10	JY
B	Added Page Three for GPS and TAS-1000.	24 JAN 13	JY
C	Added notes for single-engine installations.	1 OCT 13	JY

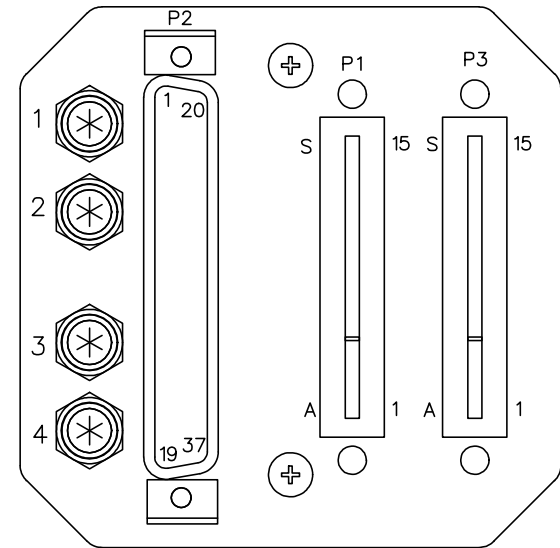
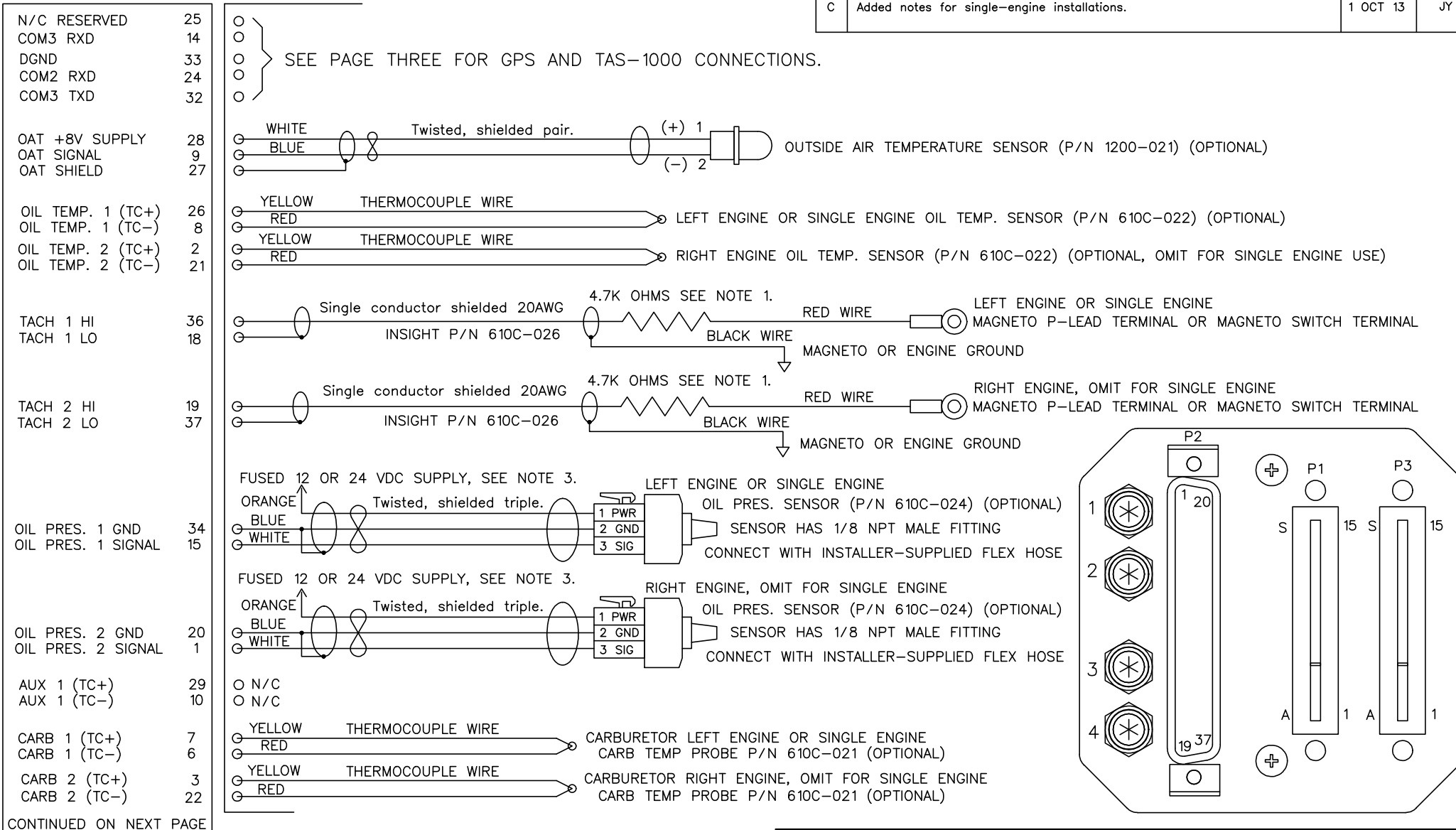

CONTINUED ON NEXT PAGE

- NOTES:
- IMPORTANT! USE INSIGHT CABLE P/N 610C-026 WITH 4,700 OHM POWER RESISTOR, ONE WATT (AS SUPPLIED).
 - FOR FUEL FLOW AND VIBRATION SENSORS SEE NEXT PAGE.
 - Connect Oil Pressure Sensor Pin 1 to same +V supply as GEM P1-Harness, Pin 3.
 - Use 24 AWG copper wire with TEFZEL or equivalent insulation unless otherwise specified.

THERMOCOUPLE WIRE			
TYPE	JACKET	POSITIVE	NEGATIVE
K	YELLOW	YELLOW	RED
J	BLACK	WHITE	RED

Insight

G4/G9 DSUB 37-PIN INTERCONNECT DIAGRAM

Insight Avionics Inc.
Box 122, Fort Erie, Ontario L2A 5M6

SIZE	FILE NAME:	DRAWING NO.	DRN	CKD	QCD	REV
NONE	G4in1C	G4-315	JY	JY	JY	C
SCALE	DATE	SHEET				
	1 OCT 13	1 OF 3				

This drawing is the property of Insight Instrument Corporation and contains confidential and proprietary information. Reproduction or unauthorized use is strictly forbidden.
© Copyright 2010

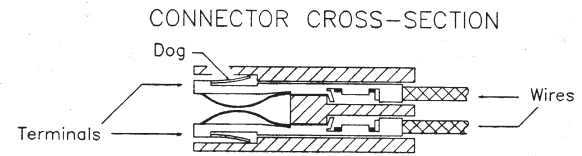
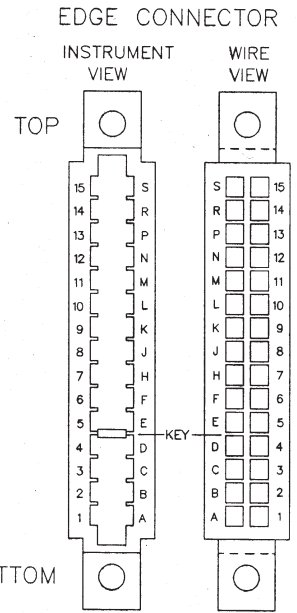

REVISIONS			
REV	DESCRIPTION	DATE	APPROVED

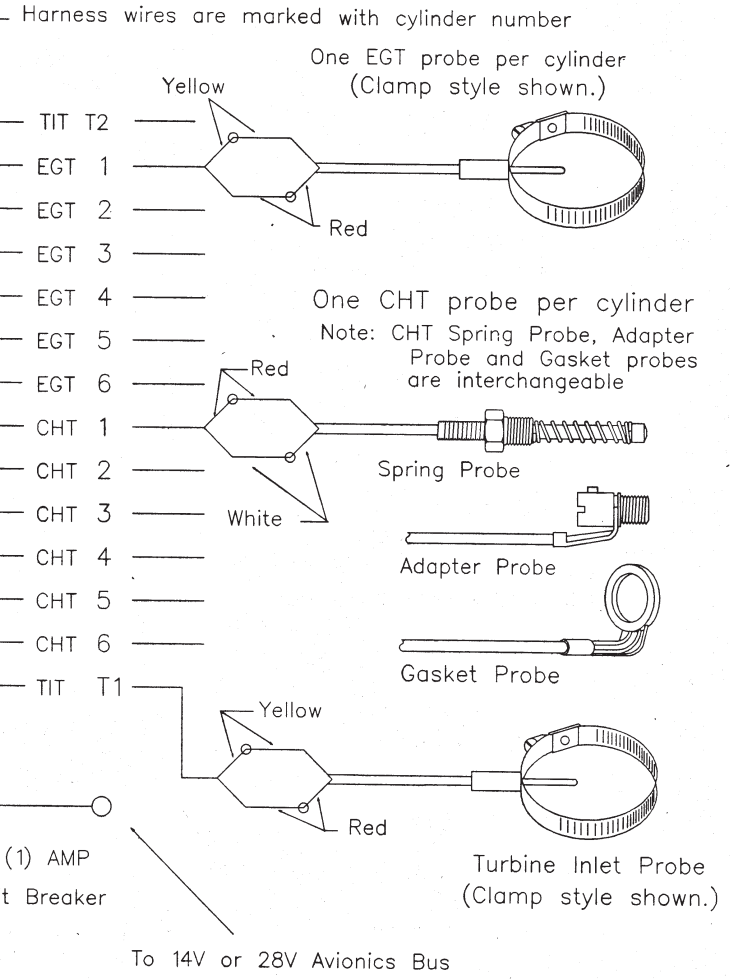
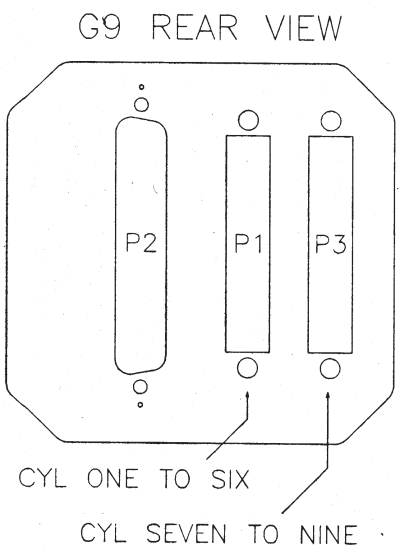
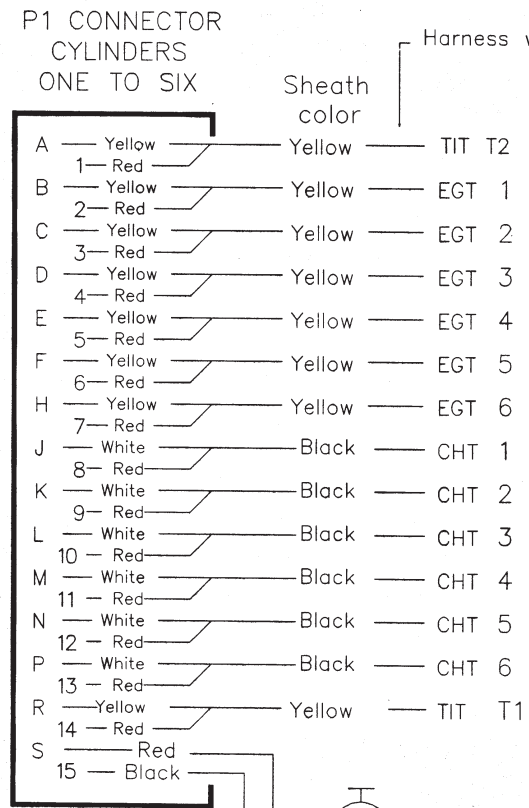
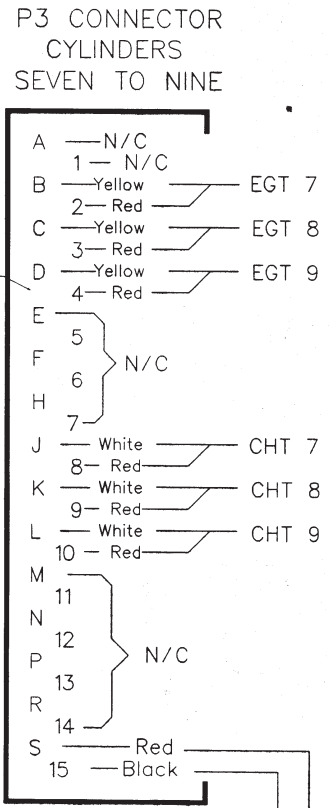

- NOTES:**
- For 7 cylinder engines omit probe wires for cylinders 8 and 9.
 - For 5 cylinder engines omit probe wires for cylinders 6 to 9.
 - Power and ground wires 24 AWG.
 - Insight EGT probes and TIT probes, clamp and screw-in type are interchangeable.

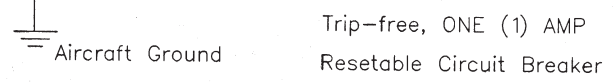

Insight

**G9 GEM WIRING DIAGRAM
(EGT/CHT/TIT FOR RADIAL ENGINE)**

Insight Instrument Corp.
Box 122, Fort Erie, Ontario L2A 5M6

SIZE A	FILE NAME: G9WIRED	DRAWING NO. 131001	DRN 98	CKD dt	QCD 98	REV -
SCALE NONE	DATE OCT 1/2013	SHEET 1 OF 1				

This drawing is the property of Insight Instrument Corporation and contains confidential and proprietary information. Reproduction or unauthorized use is strictly forbidden.
© Copyright 2011

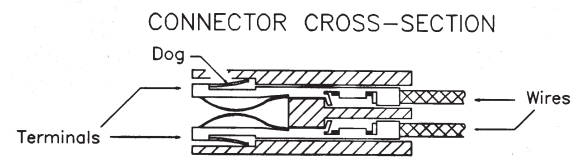
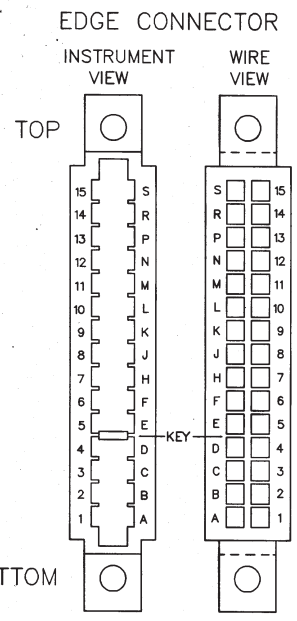

REVISIONS			
REV	DESCRIPTION	DATE	APPROVED

P1 CONNECTOR
CYLINDERS
EIGHT TO FOURTEEN

P3 CONNECTOR
CYLINDERS
ONE TO SEVEN

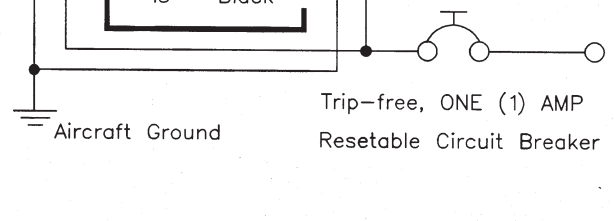
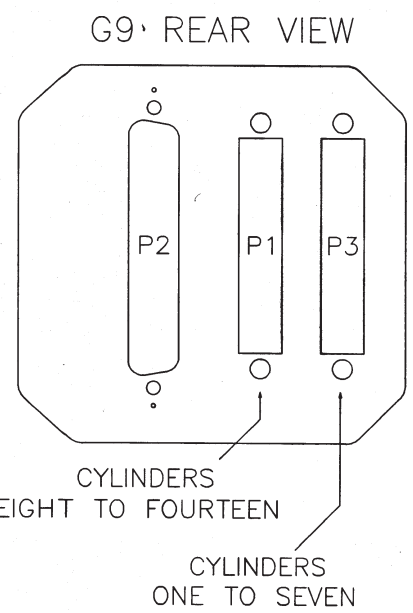
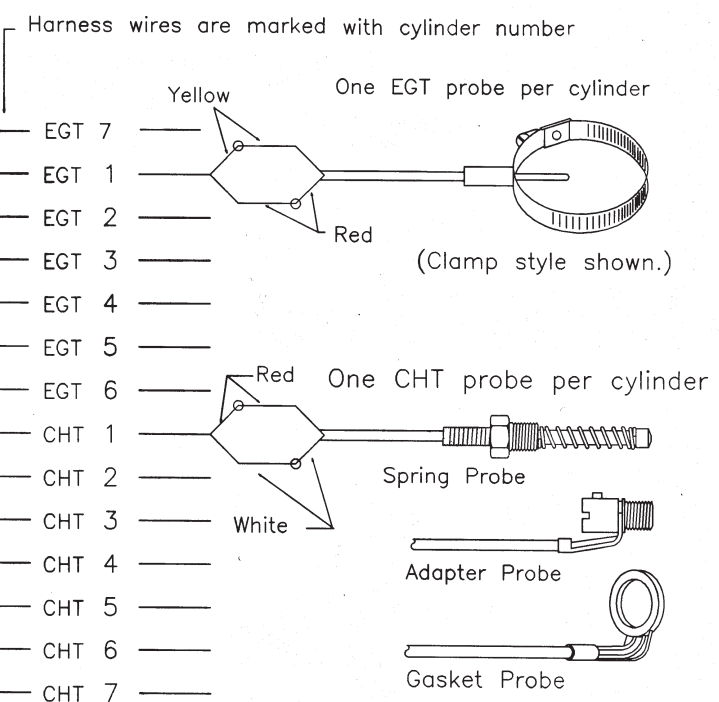
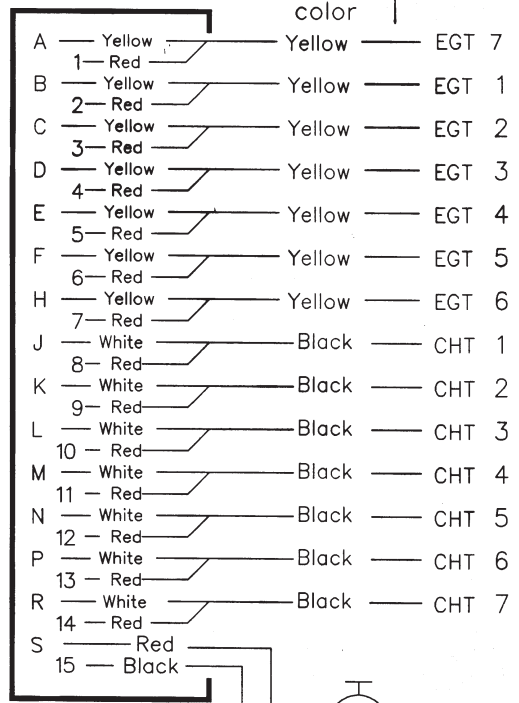
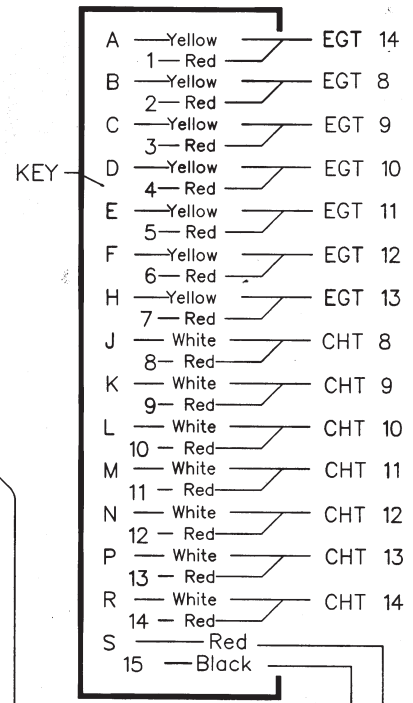

- NOTES:
1. Power and ground wires 24 AWG.
 2. Insight EGT probes and TIT probes, clamp and screw-in type are interchangeable.

Insight

G9 GEM EGT AND CHT WIRING FOR 14-CYLINDER RADIAL ENGINE

Insight Instrument Corp.
Box 122, Fort Erie, Ontario L2A 5M6

SIZE A	FILE NAME: G14WIRED	DRAWING NO. 131005	DRN <i>JS</i>	CKD <i>JS</i>	QCD <i>JS</i>	REV -
SCALE NONE	DATE OCT 1/2013	SHEET 1 OF 1				

This drawing is the property of Insight Instrument Corporation and contains confidential and proprietary information. Reproduction or unauthorized use is strictly forbidden.
© Copyright 2013